



Pipeline/valve Systems for Flushing Dairies

Charles Fulhage and Donald Pfost
Department of Agricultural Engineering

The flush water release device is a key component in dairy flush systems. Water release devices are usually built into, or are a part of the flush water storage tanks in flushing systems. The function of the water release device is to deliver flush water to the flush gutter at the proper flow rate for the proper length of time. Several types of water release devices are in common use in dairy flush systems.

1. Pipeline/valve systems
2. Tip, or rollover tanks
3. Siphons
4. Vertical rise gates, or dams

This guidesheet will discuss the pipeline/valve system and its application to flushing manure in dairy operations.

Tower/pipeline/valve flush systems

Valves are usually used in conjunction with large water-tower storage structures. Large pipes carry water from the storage tower to the flush gutter. Valves are used at appropriate locations in the pipeline to control flush water flow to individual gutters.

Figure 1 is a schematic layout of a flush system using storage towers, pipelines and valves to flush several gutters. Use of multiple, interconnected storage towers provides more storage volume, and allows feeding of the pipeline from both ends to increase flow rate through individual valves. Advantages of tower/pipeline/valve systems include:

- An ability to flush several gutters with one or two tanks;
- Relatively high pressure heads are available with tall storage towers;
- Flush volume can be varied depending on valve-open time, large flush volumes can be stored in the towers;
- Valves can be rigged for automatic control.

Disadvantages of the tower/pipeline/valve system include:

- The amount of excavation involved;
- The handling and installation of large diameter pipes;
- Valves will require some maintenance.

Storage towers are often recycled industrial steel tanks (fuel, petroleum, etc.), 25 feet or taller and 8 to 10 feet in diameter. The relatively large depth of such tanks provides the pressure head needed for adequate discharge rates in the pipeline/valve system.

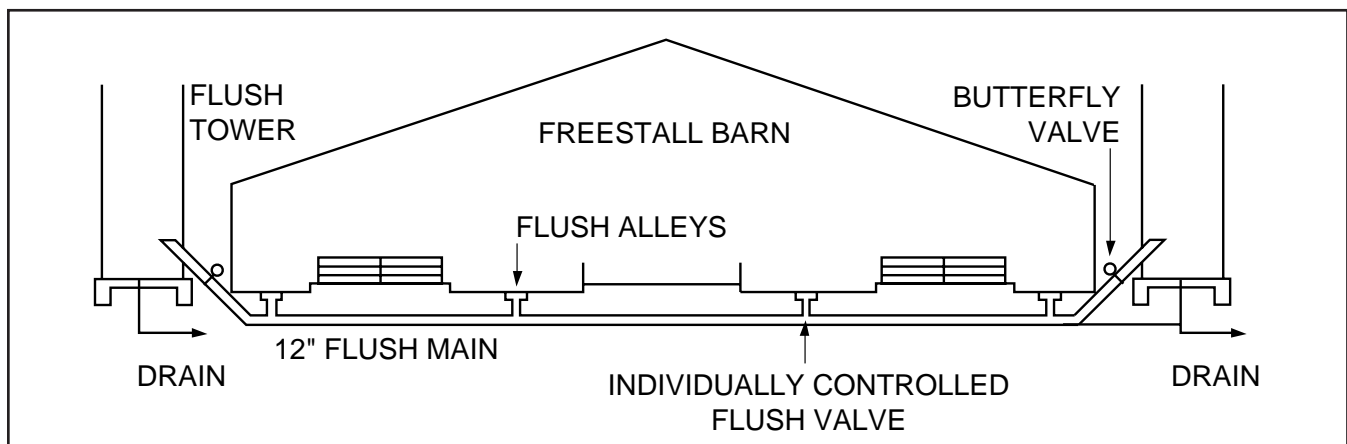

Figure 1. A typical tower/pipeline/valve flush system.

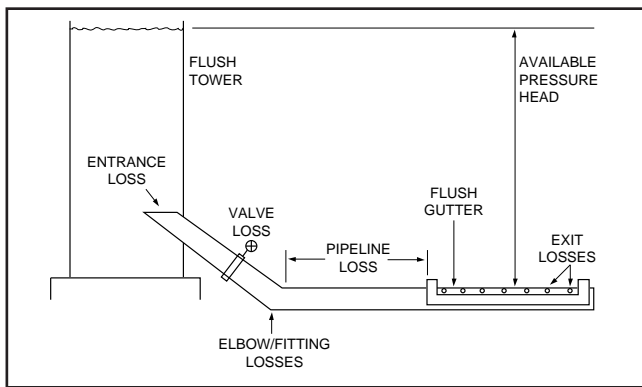

Figure 2. Typical hydraulic pressure losses in a tower/pipeline/valve flush system.

Usually, only the top third to half of the tank volume is used for flushing so that maximum pressure head is available. Storage towers should always be equipped with a drain so they can be completely emptied if needed.

Pipes used in tower/pipeline/valve systems may be either steel or PVC. PVC is generally used when the pipe will be buried or not otherwise in danger of mechanical damage. The buried pipeline system should also be installed with a drain so maintenance and freeze protection can be provided. Pipes and valves used in this application are usually 12 inches in diameter or larger.

The design of a tower/pipeline/valve flush system should be based on a detailed hydraulic analysis. The most important design consideration is the flow rate required for the gutter being flushed. The pipeline system must be designed to deliver flush water at this flow rate. See MU publication [WQ 314, Basic Requirements for Dairy Flushing](#). A detailed hydraulic analysis should take into account the hydraulic losses which occur at the required flow rate. These losses cannot exceed the available pressure head in the storage tower, or the flow rate will be reduced.

Figure 2 is a simple drawing of a pipeline/valve flush system showing the way hydraulic losses occur. The following steps outline a procedure which might be followed in developing the hydraulic design of a typical system.

1. Determine the required flow rate for the system. If the system serves more than one flush gutter, with various gutter widths, the design should be based on the gutter requiring the greatest flow rate. See MU publication [WQ 314, Basic Requirements for Dairy Flushing](#), for methods of determining flush gutter flow rate.

2. Calculate the hydraulic pressure losses which will occur at this flow rate for different component (pipe, valve, etc.) sizes.

A. Entrance losses. Entrance losses are the pressure losses that occur as water is accelerated from the static condition in the flush tower to

a high velocity in the pipeline as the valve is opened. This loss is often the greatest single loss in the system. Entrance losses can be reduced by using larger pipe sizes, and/or modifying the flow conditions into the pipe. The use of a flared or bellmouth entrance into the pipe can reduce entrance losses sufficiently to allow the use of a smaller pipe size in some cases. Hydraulic design handbooks can be used to determine applicable entrance losses.

B. Valve loss. Valves of any type represent some flow restriction in the pipeline, and thus are a source of hydraulic pressure loss. Consult manufacturer's data for the specific valve being used to determine valve loss.

C. Elbow/fitting losses. Any elbows or fittings such as tees, wyes, reducers, etc. are a source of hydraulic loss. Generally, the designer should attempt to minimize the number of fittings used in the system, and to use fittings in a manner to minimize hydraulic losses. For example, the pipe in Figure 2 could exit vertically out the bottom of the flush tower, followed by a 90 degree elbow. However, this configuration would have a much higher pressure loss than the single 45 degree elbow shown. Hydraulic design handbooks are a source of information on fitting losses.

D. Pipeline loss. This pressure loss is due to friction retarding flow in straight sections of the pipeline. The total length of straight pipe, pipe size and pipe roughness determine the friction or pipeline loss. Hydraulic design handbooks include information on determining friction losses in pipes.

E. Exit loss. Exit losses occur at the point of discharge of flush water from the pipe. These losses can range from very minimal, in the case of open-pipe discharge, to significant depending upon the type of discharge device used. The gated-pipe discharge, which is designed to distribute water evenly over the width of the gutter, requires some pressure loss in order to accomplish this even distribution. Some commercial flush valves have the distribution device built integrally with the valve, and losses in these cases are generally described as a combined valve and discharge loss. Hydraulic handbooks and computer hydraulic software can be used in designing discharge and distribution devices.

3. After all applicable pressure losses have been determined for the various pipe sizes, they must be summed and compared to the available pressure head in the flush tower. The pipe size and components whose summed pressure losses most nearly

equals the available pressure head in the flush tower should be selected.

The above discussion and Figure 2 represent a very simple system. Many systems may involve more than one flush tower, with water flowing through more fittings to valves or discharge points from two different directions. Such systems are more tedious and time-consuming to analyze hydraulically. The services of a qualified engineer, experienced in hydraulic design can be very helpful in developing a pipeline/valve flush system which will perform as intended.

Types of valves and discharge devices

Several types of valves and discharge devices are currently in use in pipeline/valve systems. However, all types of valves and discharge devices typically use a tower for flush water storage. The following discussion describes some different types of valves and discharge devices in common use for flushing dairies.

Butterfly valves

Butterfly valves are relatively simple valves that rotate to open and close like a damper in a stovepipe. See Figure 3. Valve bodies are usually cast iron with seals around the stem and perimeter of the valve opening to ensure that flow is stopped in the closed position. Butterfly valves can be obtained in sizes 2 to 24 inches in diameter, however, most common sizes for dairy flushing are 12 to 18 inches. Butterfly valves are usually constructed for flange-type connections to the pipeline. Valve distributors can usually provide valves equipped for field connection to either steel or PVC pipe. Methods of opening and closing butterfly valves include the simple lever, gear operated, and automatic actuators.

With a simple lever, the lever is rotated 90 degrees to provide full valve opening. Advantages of this method are its low cost and simplicity. Disadvantages include the relatively large forces required to move the lever on larger valves, and the possibility that the valve can be closed too quickly, resulting in water hammer. Some cases of burst pipelines have occurred with lever-operated valves because they were closed too quickly.

Gear-operated butterfly valves have a handwheel that is turned several revolutions to open and close the valve. This arrangement provides a mechanical advantage to reduce the force required to open and close the valve, and prevents the valve from being opened or closed too quickly, thus preventing water hammer and the associated potential for burst pipes. Because of these advantages, the gear-operated butterfly valve is usually the best choice for dairy flushing applications.



Photo courtesy FMC, Houston, Texas

Figure 3. A typical butterfly valve.

Butterfly valves can be equipped with air or electric actuators to operate the valve in a powered mode, either automatically according to a timer, or manually with the “flip of a switch.” These features add considerably to the cost of the valve, and are generally not considered necessary by most dairy producers.

Butterfly valves are designed to be installed in a pipeline to regulate flow, and so do not provide a means of discharging or distributing water into a flush gutter. Several types of discharge/distribution devices can be used downstream from butterfly valves to discharge water into a flush gutter.

Open-pipe discharge

A simple means of discharging water into a flush gutter downstream from a butterfly valve is the open-pipe discharge shown schematically in Figure 4.

The primary advantages of this arrangement are simplicity and minimal pressure head loss at the dis-

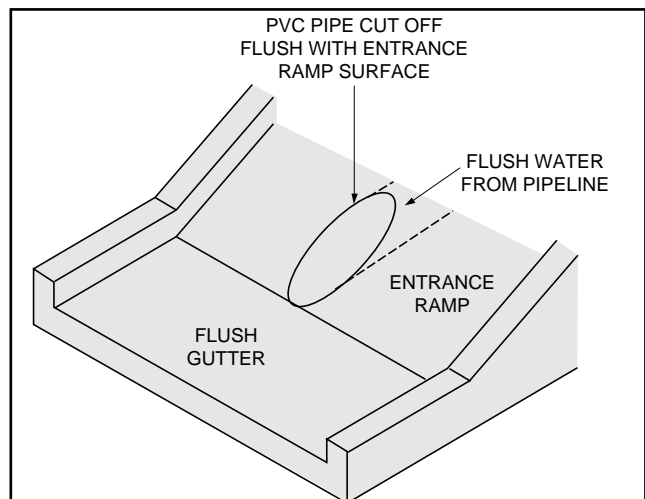

Figure 4. Schematic of an open-pipe discharge.

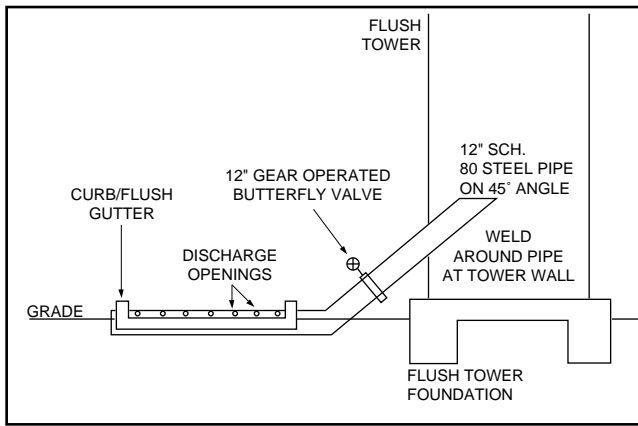

Figure 5. Schematic of a typical gated pipe discharge for flushing.

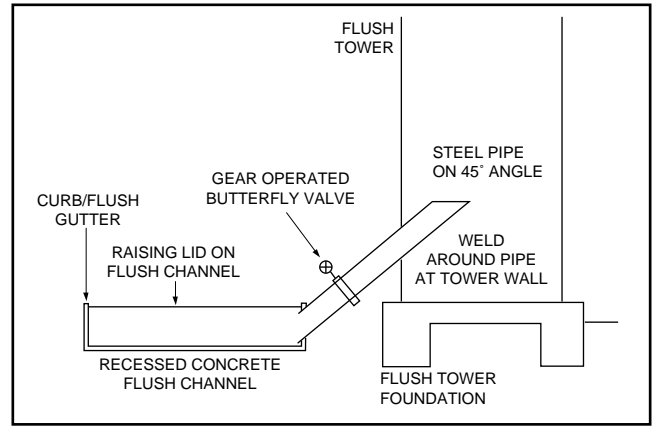

Figure 7. Concrete flush channel with raising-lid discharge.

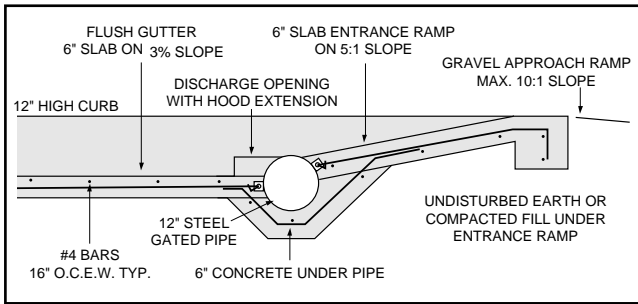

Figure 6. Cross-section of a typical gated pipe discharge.

charge point. A disadvantage of this arrangement includes poor distribution of flush water over the full width of the gutter at the upper end. For this reason, this type discharge is usually used on narrower gutters (10 feet or narrower). Another disadvantage of this type discharge is the relatively steep entrance ramp slope required. Such a steep slope (typically 2:1 to 3:1) may be a hindrance to animal or vehicular traffic.

Gated pipe discharge

A gated pipe discharge device provides more even distribution of flush water at the point of discharge into the flush gutter. As shown in Figures 5 and 6, a series of holes of the proper size is cut into the top periphery of a steel pipe, and the pipe is recessed into the floor of the flush gutter so that protrusion above the floor of the gutter is limited to 3 to 4 inches. Hole size depends upon the pressure head available. The gated pipe should be hydraulically designed to provide reasonably even distribution of water over the width of the flush gutter. Advantages of this method of discharging water include even distribution, the ability to impart a high initial discharge velocity to the flush water and the low profile of the pipe in the gutter which is easily crossed by vehicular or animal traffic.

Raising lid discharge

Another means of introducing water into a flush gutter downstream from a butterfly valve is the rais-

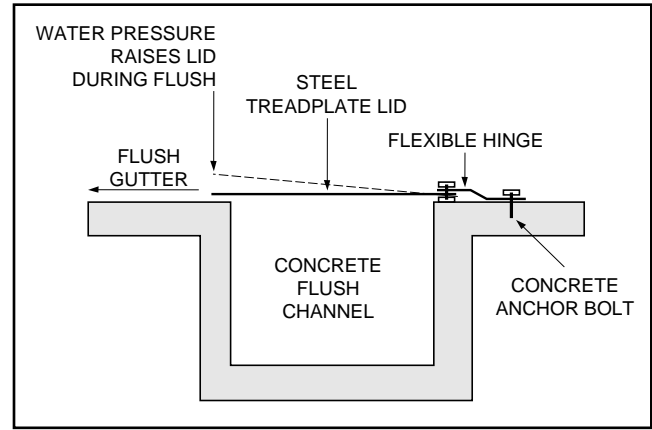
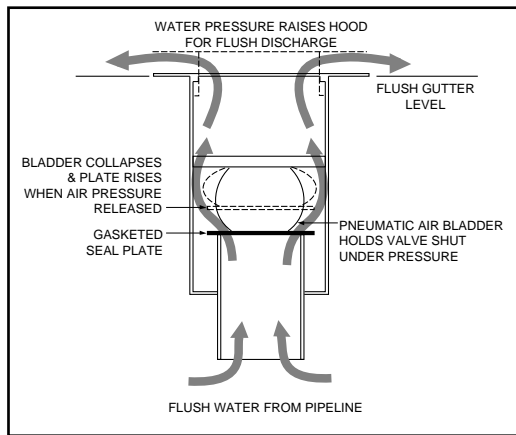

Figure 8. Cross-section of raising-lid flush channel.

ing lid discharge. This device is a recessed concrete channel across the gutter or area to be flushed. The channel is equipped with a steel treadplate lid that is hinged along the upstream edge of the channel. As flush water is introduced into the channel, water pressure lifts the lid, and water flows out of the channel and down the flush gutter. The lid is restrained to provide the proper discharge opening size so that water is discharged evenly over the width of the area being flushed. The concrete channel is fed by a steel or PVC pipe which introduces water at one end of the channel. Figures 7 and 8 show schematically the details of a raising lid discharge. Typical width and depth of these flush channels ranges from 18 to 24 inches. The primary advantage of this type of discharge is the ability to distribute large volumes of flush water evenly over relatively wide areas. In some cases it may be desired to flush areas (holding pens, etc.) which may be 30 to 40 feet wide. A gated-pipe discharge might require a prohibitively large pipe in such cases, but the proper cross section for adequate flow can be more reasonably obtained with a recessed concrete channel. Another advantage of a raising lid is that there is no protrusion above the level of the flush gutter (except during flushing), so there are no impediments to animal or vehicular traffic, because



Courtesy Agpro, Inc. Paris, Texas

Figure 9. Schematic of a pneumatically-actuated recessed valve.

the lid lies flat on the concrete channel except during flushing.

Recessed valves

Another type of water release device commonly used in dairy flushing is the recessed valve. These devices are usually either pneumatically or manually operated, and are configured to be installed entirely below the grade of the flush gutter. As the valve is opened, water pressure raises a discharge/distribution hood to allow water to flow down the gutter. This feature has led to these valves being commonly referred to as “pop-up” valves. These valves combine both the water release function and the discharge/distribution function in a single unit, in contrast to the butterfly valve and accompanying discharge/distribution devices discussed above.

Pneumatically actuated recessed valves close under air pressure, so a source of compressed air is required for operation of these valves. Because air pressure maintains these valves in the closed position, loss of air pressure will result in the valve opening (perhaps inadvertently) and emptying of the flush tower.

Recessed valves have the advantages of completely below-grade design, and the combined valve and discharge/distribution function. A disadvantage of the recessed valve is that it is generally commercially obtainable in a limited number of sizes, and so may not be precisely fitted to the flush requirements of the gutter being considered. Recessed valves may not be capable of providing adequate flow to wide (15 feet or wider) gutters. Installing more than one valve in a wide gutter and discharging both simultaneously usually is not a suitable approach unless the individual valves are fed by individual pipes from the flush tower. Discharge rate from recessed valves is most influenced by the hydraulic characteristics of the pipeline(s) feeding the valve, rather than the valve itself. The discharge rate

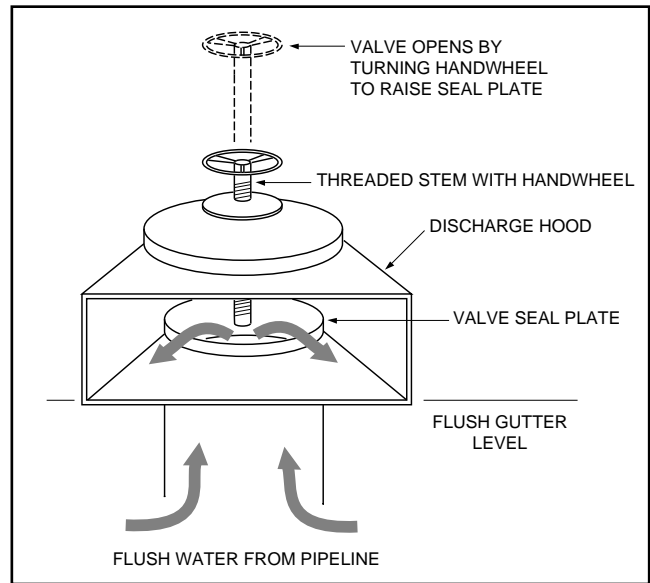

Courtesy Fresno Valves and Castings, Lubbock, Texas

Figure 10. Schematic of an above-grade valve.

of recessed valves is increased significantly if the valve is fed from both sides as in the configuration of Figure 1.

Above grade valves

Another type valve used in dairy flushing is the above-grade valve opened by a handwheel/stem arrangement similar to a globe valve (See Figure 10). Similar to recessed valves, these valves also combine the valving and discharge/distribution in a single unit. Since these valves protrude above grade, and the stem and handwheel rise as the valve is opened, they have to be located to the side of the alley being flushed if vehicular or animal traffic needs to traverse the gutter. With such a side location, water is not discharged directly down the gutter as with the other release/discharge devices discussed. However, these valves should be mounted and aligned to discharge water as nearly as possible down the gutter to prevent excessive splashing and curb height requirements.

The primary advantage of the above grade valve is its simplicity and ease of construction. As with recessed valves, flow rate through an above grade valve is increased significantly if the valve is fed from both sides.

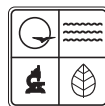

This guide was published with funds provided to the Missouri Department of Natural Resources from the Environmental Protection Agency, Region VII. To learn more about water quality and other natural resources, contact the Missouri Department of Natural Resources, P. O. Box 176, Jefferson City, MO 65102. Toll free 1-800-334-6946.



OUTREACH & EXTENSION
UNIVERSITY OF MISSOURI
COLUMBIA

■ Issued in furtherance of Cooperative Extension Work Acts of May 8 and June 30, 1914, in cooperation with the United States Department of Agriculture. Ronald J. Turner, Interim Director, Cooperative Extension, University of Missouri and Lincoln University, Columbia, Missouri 65211.
■ An equal opportunity institution.